

XRT83SL38/L38 OCTAL LONG HAUL, SHORT HAUL LIU MAIN INTERFACE

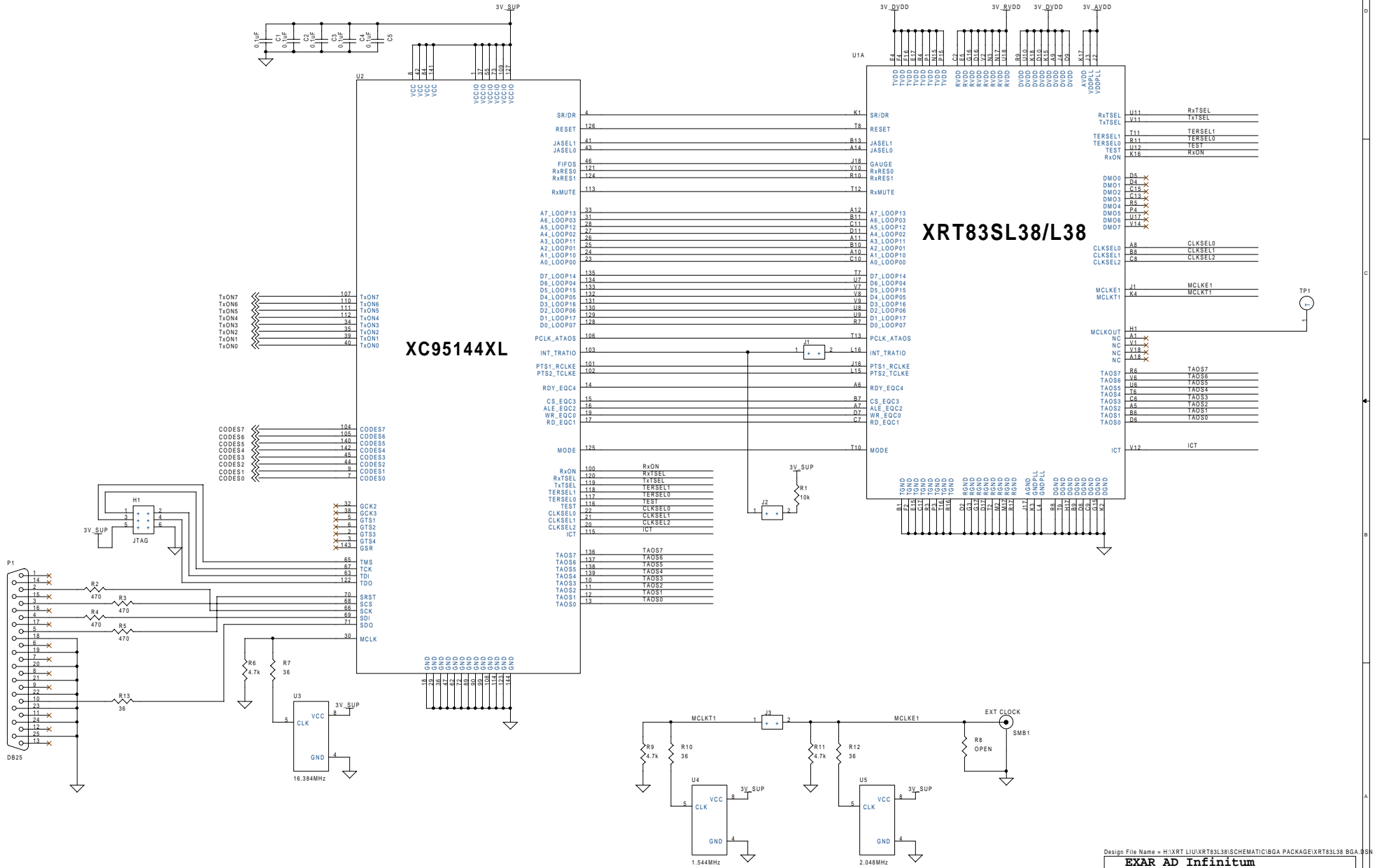

XRT83SL38/L38

XC95144XL

Design File Name = H:\XRT\LIU\XRT83SL38\SCHEMATIC\BGA PACKAGE\XRT83SL38 BGA 57M

EXAR AD Infinitum		
File	XRT83SL38/L38	
Size	Document Number	Rev
C	XRT83SL38/L38 LONG HAUL, SHORT HAUL LIU	D
Date:	Tuesday, November 05, 2002	Sheet 1 of 3

POWER CIRCUITRY

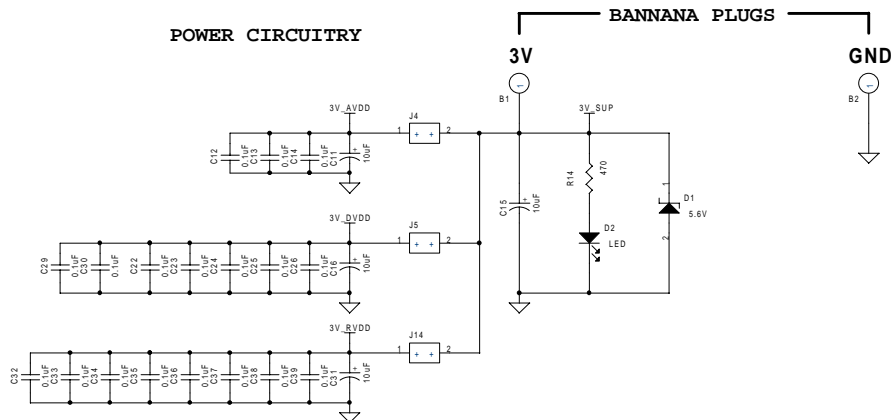

GROUND POINTS

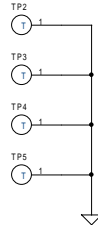

MOUNTING HOLES

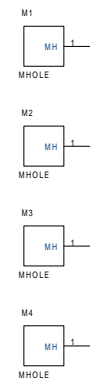

LIU TRANSMIT AND RECEIVE

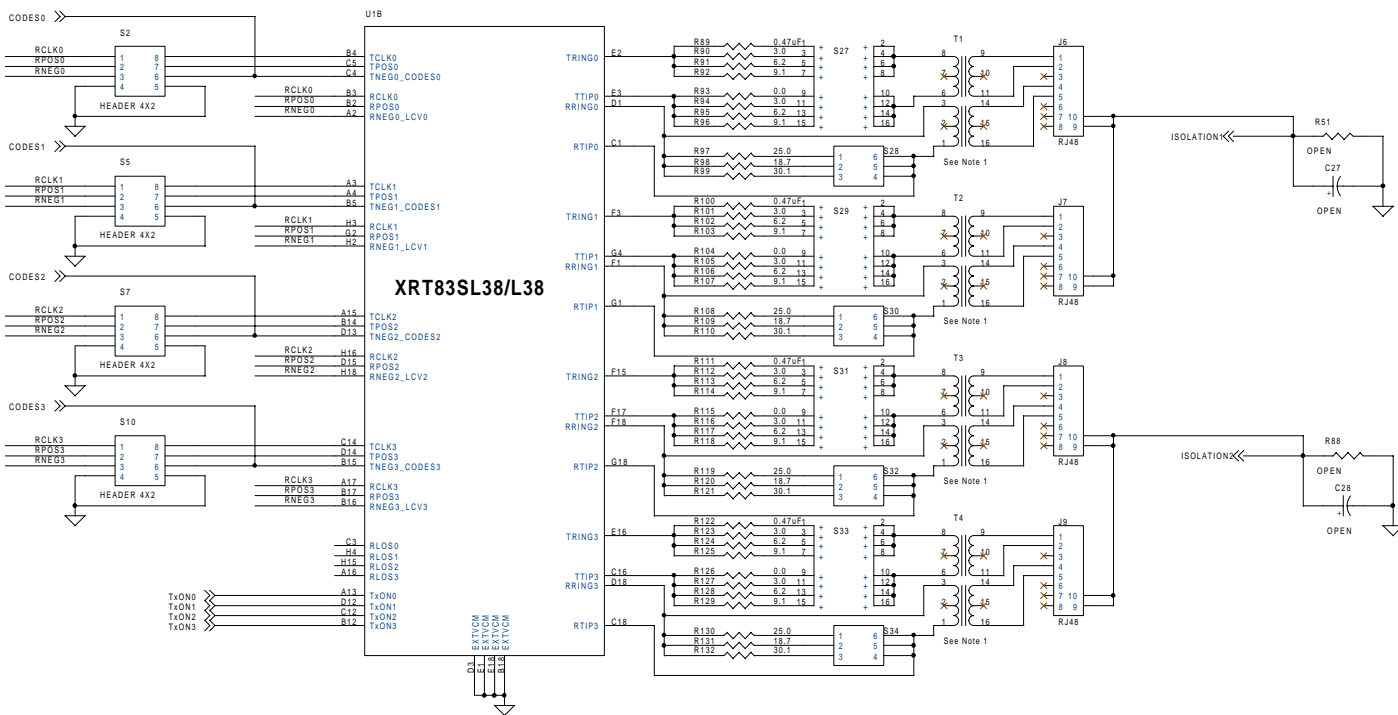

Tx=1:2, Rx=1:1
Note 1: Transformer Selection
 TRANSPOWER SMD606-05
 HALO TG74-1505N1

LIU TRANSMIT AND RECEIVE

